

## ROR Trailer Products

Tyre Inflation System by P.S.I.™

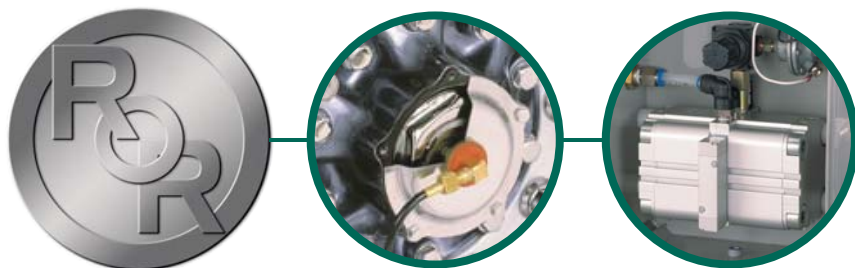

choose for reliability . . .  
choose for quality . . .  
choose for robustness . . .

*. . . your profitability is our concern*

**ArvinMeritor™**

# ROR Tyre Inflation System by P.S.I.™

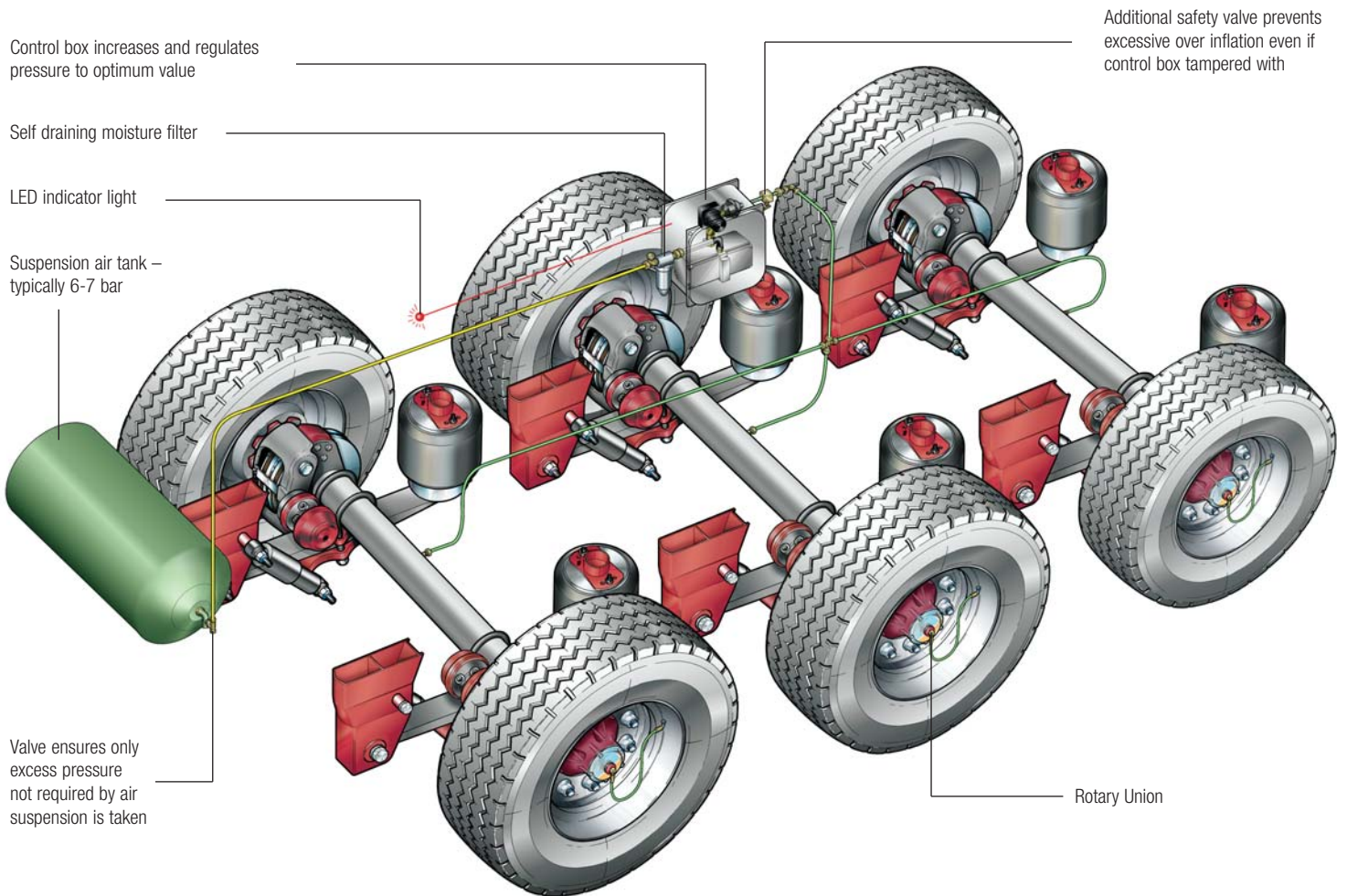

## Under-Inflated Trailer Tyres Cost Time, Fuel and Money

Tyres represent the second largest financial expenditure for most fleets. Tyre manufacturers claim a 20% reduction in the required pressure will reduce a tyre's total mileage capability by 25%. On top of this the trailer will tend to create more drag with under-inflated tyres compromising fuel economy. ArvinMeritor tests over the last 12 months on vehicles with and without the ROR Tyre Inflation System by P.S.I.™ achieved an average improvement of 0.2 mpg once the system was fitted. This could represent alone £1,200 of diesel over 12 months! "Maintaining tyre inflation pressure is the single most important tyre maintenance function. Cost per mile will directly benefit from consistent tyre pressure control" – Goodyear.

Loss of inflation due to punctures or blowouts can dramatically increase cost of ownership and create hazardous on- and off-road situations. Blowouts can also cause costly damage to the trailer running gear, bumpers, mud-flaps etc. not to mention the loss of up-time this creates.

## The Solution

The new concept from ArvinMeritor "ROR" is to drive down fleet costs and simplify life for the operator. To this end the ROR Tyre Inflation System by P.S.I.™ addresses all the problems and quickly pays back the original investment, often within 12 months. (Contact ArvinMeritor to see how quickly the system would pay for itself with your specific fleet's cost structure).



### How It Works

The ROR Tyre Inflation System by P.S.I.™ actually MAINTAINS correct cold temperature tyre pressure utilising surplus air from the air suspension tank of the trailer.

- Surplus air, not required for the suspension operation, is routed through a control box where the pressure is doubled via an air operated step-up pump and regulated to the optimum tyre pressure required. It is then fed into each sealed axle.
- Acting as a conduit, the axles carry air through a rotary union assembly at the spindle end, which then distributes air to each tyre as needed. (Rotary Unions take only moments to replace and typically last for in excess of 300,000 miles).
- A LED indicator light informs the driver of any excessive air pressure loss caused by a puncture so that the driver knows instantly of any problem. In most cases the system

can keep up with the pressure loss caused by the puncture in any case saving the tyre and related damage as well as the obvious safety benefit.

- Should a tyre failure occur, check valves in the tyre delivery lines prevent any loss of pressure from other tyres.

### Easy to Install

ROR Tyre Inflation System by P.S.I.™ can be specified factory fitted for any new trailer with ROR axles and axles arrive pre-leak tested, drilled and fitted with ROR Tyre Inflation System by P.S.I.™ wheel end components ready for simple installation by the O.E.M. Aftermarket kits are available for fitment to any existing trailer.

ArvinMeritor offers complete installation and training support. The system is designed to work with any tractor and is supported by a full 2 Year Warranty covering all components.



## ROR Tyre Inflation System Benefits

- Reduced maintenance costs
- Less trailer downtime
- More on-time deliveries
- Increased safety
- Reduced trailer damage
- Longer tyre life
- Improved fuel economy

**ArvinMeritor Inc.**

World Headquarters  
2135 West Maple Road  
Troy, Michigan 48084  
U.S.A.  
Tel: +1 248 435 1000

**Meritor HVS Limited**

Commercial Vehicle Systems  
Rackery Lane, Llay  
Wrexham LL12 0PB  
U.K.  
Tel: +44 (0)1978 852141  
Fax: +44 (0)1978 856173

**Meritor HVS (Verona) s.r.l.**

Commercial Vehicle Systems  
Via Monte Fiorino, 23  
37057 San Giovanni Lupatoto, Verona  
Italy  
Telephone: +39 045 8750399  
Fax: +39 045 8750640 / 8750513

**Meritor HVS (Barcelona) S.A.**

Commercial Vehicle Systems  
Ctra. Granollers - Sabadell Km. 13,3  
Poligono Argelagues  
08185 Lliçà de Vall  
Spain  
Tel: +34 (9)3 843 95 68  
Fax: +34 (9)3 843 83 59

**Meritor HVS (Mitry-Mory) S.A.**

Commercial Vehicle Systems  
Z.I. du Moulin à Vent  
9 rue des Frères Lumière  
77290 Mitry-Mory  
France  
Tel: +33 (0)1 64.27.44.61  
Fax: +33 (0)1 64.27.30.45

**ArvinMeritor**

Commercial Vehicle Systems  
Postbus 255, 5700AG Helmond  
Churchillaan 204A, 5705BK Helmond  
The Netherlands  
Tel: +31 (0)492 535805  
Fax: +31 (0)492 547175

**ArvinMeritor South Africa**

Commercial Vehicle Systems  
Tel: +27 (0) 83 602 1603

www.rorcare.com  
www.arvinmeritor.com

**ArvinMeritor**

Commercial Vehicle Aftermarket AG  
Neugutstrasse 89  
8600 Dübendorf  
Switzerland  
Tel: +41 (0)1 824 8200  
Fax: +41 (0)1 824 8265

**ArvinMeritor**

Commercial Vehicle Aftermarket Ltd.  
Park Lane, Great Alne, Alcester  
Warwickshire B49 6HT  
U.K.  
Tel: 0845 606 7733  
Fax: 0845 606 8844

**ArvinMeritor**

Commercial Vehicle Aftermarket  
*Ireland*  
Tel: +44 1789 768221  
*The Netherlands*  
Tel: 0900 202 0348  
*Belgium*

Tel: 078 15 13 72

*Luxembourg*

Tel: 27302012

*France*

Tel: 0810 811 267

*Spain*

Tel: 901 512 214

*Portugal*

Tel: 808 200881

*Italy*

Tel: 848 881 078

*Germany*

Tel: 01801 000402

*Austria*

Tel: 0810 810041

*Scandinavia*

Tel: +44 1789 768259

Descriptions and specifications were in effect at the time of publication and are subject to change without notice or liability. Meritor reserve the right to make design improvements, change or discontinue parts at any time.

© Copyright 2004  
Meritor Automotive  
All rights Reserved

Issued 02-04  
Publication 4.93.2



**ArvinMeritor™**